

**ULTRA LOW DISTORTION  
LINE MATCHING TRANSFORMER****P3146****Features**

- \* Ultra-Low Distortion
- \* 12.6mm (0.5") seated height
- \* Extended Frequency Response
- \* IEC 950, UL 1950 and EN 60950 certified
- \* UL Recognized Component
- \* BAPT Certificate of Recognition
- \* CSA NRTL/C Certificate of Compliance
- \* Flat TX and RX Responses
- \* High Thermal Stability

**Applications**

- \* V.90 and V.92 modems

**DESCRIPTION**

P3146 is intended for V.90 and V.92 (56kbps) modems and other high-speed applications where ultra-low distortion at high power levels and very low voiceband frequencies is required.

P3146 is mechanically compatible with industry standard P1200 and P2001.

P3146 has extended flat frequency response from 30Hz to 4kHz with very low levels of signal distortion at signal frequencies as low as 150Hz.

P3146 also exhibits stable characteristics over its operating temperature range to maximize data throughput under varying environmental conditions without the need for modem retraining.

P3146 meets international safety standards, being vacuum encapsulated and 100% tested to withstand 6.5kV.

P3146 is certified to IEC 950, EN 60950, UL1950 and EN 41003. P3146 is a UL Recognized Component and is supported by a BAPT Certificate of Recognition, a CSA Certificate of Compliance and an IEC CB Test Certificate.



## SPECIFICATIONS

### Electrical

At T = 25°C and as circuit Fig. 2 unless otherwise stated.

| Parameter                                | Conditions                             | Min        | Typ  | Max | Units |       |
|--|--|------------|------|-----|-------|-------|
| Insertion Loss                           | f = 2kHz, R <sub>L</sub> = 510Ω        | -          | 2.5  | -   | dB    |       |
| Frequency Response                       | LF -3dB cutoff                         | -          | 10   | -   | Hz    |       |
|  | HF -3dB cutoff                         | -          | 6    | -   | kHz   |       |
|  | 100Hz - 4kHz                           | -          | ±0.6 | -   | dB    |       |
| Return Loss                              | 200Hz - 4kHz                           | 16         | -    | -   | dB    |       |
| Third Harmonic Distortion <sup>(1)</sup> | 450Hz 0dBm in line                     | -          | -90  | -   | dBm   |       |
|  | 150Hz -3dBm in line                    | -          | -81  | -   | dBm   |       |
| Saturation                               | Excitation 50Hz                        | -          | -    | 10  | Vrms  |       |
|  | 250Vrms.<br>Output voltage across line | -          | -    | 65  | Vpeak |       |
| Voltage isolation <sup>(2)</sup>         | 50Hz                                   | 3.88       | -    | -   | kVrms |       |
|  | DC                                     | 5.5        | -    | -   | kV    |       |
| Operating range:                         | Ambient temperature                    | Functional | -10  | -   | +70   | °C    |
|  |  | Storage    | -40  | -   | +125  | °C    |
|  |  | Humidity   | -    | -   | 95    | %R.H. |

Lumped equivalent circuit parameters as Fig. 1

|  |                 |   |     |   |    |
|--|-----------------|---|-----|---|----|
| DC resistance, R <sub>DC</sub> <sup>(3)</sup>  | Sum of windings | - | 200 | - | Ω  |
| Leakage inductance ΔL                          |                 | - | 25  | - | mH |
| Shunt inductance L <sub>p</sub> <sup>(4)</sup> | -43dBm 200Hz    | - | 14  | - | H  |
| Shunt loss R <sub>p</sub> <sup>(4)</sup>       | -43dBm 200Hz    | - | 25  | - | kΩ |

### Notes

1. Third harmonic typically exceeds other harmonics by 10dB.
2. Components are 100% tested at 6.5kV DC.
3. Caution: do not pass DC through windings. Telephone line current, etc. must be diverted using semiconductor line hold circuit.
4. At signal levels greater than -20dBm, L<sub>p</sub> will increase and R<sub>p</sub> will decrease slightly but the effect is usually favourable to the return loss characteristic.

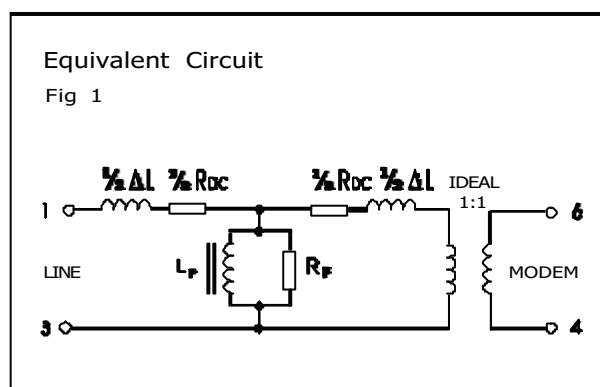

## MATCHING RECOMMENDATIONS

### 600Ω MATCH

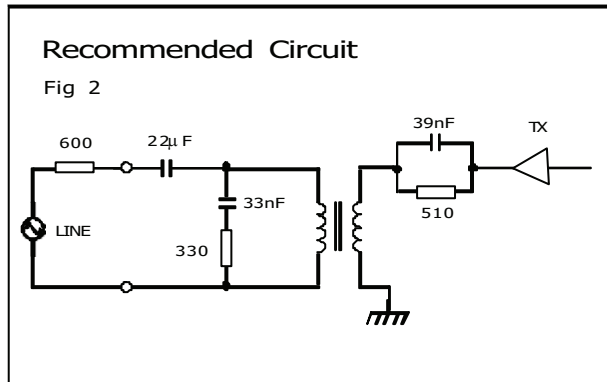

### EUROPEAN CTR21 COMPLEX MATCH

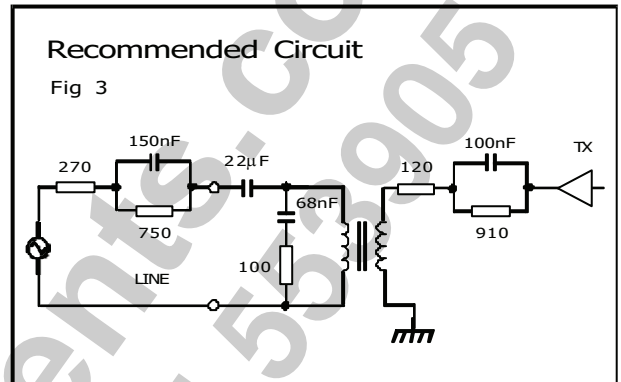

## CONSTRUCTION

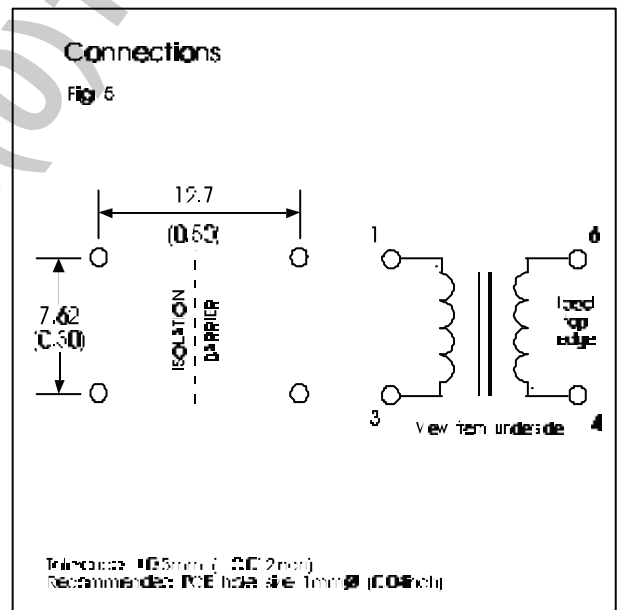
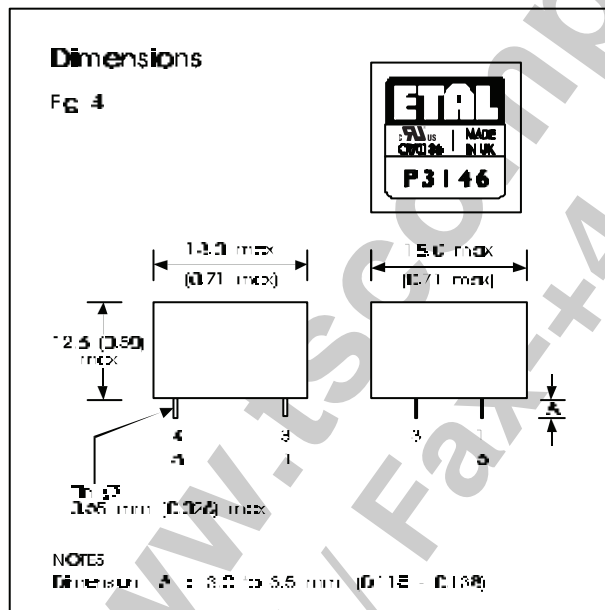

Dimensions shown are in millimetres (inches).  
Geometric centres of outline and pin grid coincide within a tolerance circle of 0.6mmØ.  
Windings may be used interchangeably as primary or secondary.

## SAFETY

Constructed in accordance with IEC 950:1991, EN60950:1992 (BS7002:1992) to amendment 5, supplementary insulation, and UL 1950 3rd Edition, reinforced insulation, 250Vrms maximum working voltage, flammability class V-0.

Distances through solid insulation 0.4mm minimum.

## CERTIFICATION

Certified under the IEC CB scheme (Certificate GB442W) to IEC 950:1991, up to amendment 4, sub-clauses 1.5, 1.5.1, 1.5.3, 2.2, 2.2.2, 2.2.3, 2.2.4, 2.9.2, 2.9.3, 2.9.4, 2.9.6, 2.9.7, 4.4, 4.4.3.2 (class V-0) and 5.3 for a maximum working voltage of 250Vrms, nominal mains supply voltage not exceeding 300Vrms and a maximum operating temperature of 70°C in Pollution Degree 2 environments, supplementary insulation.

Recognized under the Component Recognition Program of Underwriters Laboratories Inc. to US and Canadian requirements CAN/CSA C22.2 No. 950-95/UL1950, Third Edition, including revisions through to revision date March 1, 1998, based on Fourth Amendment of IEC 950, Second Edition, maximum working voltage 250Vrms, Pollution Degree 2, reinforced insulation.

UL File number E203175.

CSA Certificate of Compliance 1107696 (Master Contract 188107).

Approved and certified by BABT to EN 60950 and EN 41003.

BABT Certificate of Recognition CR/0136.

Additionally, Profec Technologies certifies all transformers as providing voltage isolation of 3.88kVrms, 5.5kV DC minimum. All shipments are supported by a certificate of conformity to current applicable safety standards.

## ABSOLUTE MAXIMUM RATINGS

(Ratings of components independent of circuit).

Short term isolation voltage (15s) 4.6kVrms,  
6.5kVDC

DC current 100µA

Storage temperature -40°C to  
+125°C

Lead temperature, 10s 260°C

## COPYRIGHT

ETAL, P3146, P1200 and P2001 are Trade Marks of Profec Technologies Ltd.

The Trade Mark ETAL is registered at the UK Trade Marks Registry.

Profec Technologies Ltd. is the owner of the design right under the Copyright Designs and Patents Act 1988 and no rights or licences are hereby granted or implied to any third party.

© 1997, 1999 and 2000 Profec Technologies Ltd. Reproduction prohibited.

**PROFEC**  
TRANSFORMING THE FUTURE



ISO 9001  
FM 25326

Profec Technologies Ltd., 10 Betts Avenue, Martlesham Heath, Ipswich, IP5 3RH, England

Telephone: +44 (0) 1473 611422

Websites: [www.etal.ltd.uk](http://www.etal.ltd.uk)

Email: [info@etal.ltd.uk](mailto:info@etal.ltd.uk)

Fax: +44 (0) 1473 611919

[www.profec.com](http://www.profec.com)

[sales@profec.com](mailto:sales@profec.com)